



## AIRCLEAN POLLUTION CONTROL PTE LTD

乙弘环境污染净化设备

1 Yishun Industrial Street 1, #06-11, A'Posh Bizhub, Singapore 768160

Telephone : 6458-2868 Fax : 6458-7828

Website : [www.aircleanpc.com](http://www.aircleanpc.com) Email : [sales@aircleanpc.com](mailto:sales@aircleanpc.com)



### FRP Dilution Tank

Description:

From the design & fabrication to tank & piping installation at site, we offer turn-key solutions to your wastewater dilution needs.

Our dilution tanks are suitable for laboratories where they are installed below lab benches and sinks for local dilution before channelling to the main drain.

Our FRP constructed dilution tanks can be custom designed to suit site requirements where space might be a concern.

All our dilution tanks come with internal baffle plates for longer retention time and removable top cover for easy maintenance.

***\* For enquiries on centralized dilution tank, please contact us for further details.***





# AIRCLEAN POLLUTION CONTROL PTE LTD

乙弘环境污染净化设备

1 Yishun Industrial Street 1, #06-11, A'Posh Bizhub, Singapore 768160

Telephone : 6458-2868 Fax : 6458-7828

Website : www.aircleanpc.com Email : sales@aircleanpc.com

## Technical Specification

Product	: Fibreglass Dilution Tank c/w Internal Baffles
Application	: Localised Dilution for Laboratory Sinks
Top Cover	: Boltless / Bolted Removable Top Cover
Thickness	: Approx. 4 mm
Type of Fabrication	: Handlay
Material of Construction	: FRP
Tank Nozzles	: $\varnothing 1\text{-}1/2\text{'}$ Inlet & Outlet (Union or Female Adapter)
Optional Accessories	: Internal Removable Fibreglass Basket Strainer

## Dilution Tank Schematic Diagram (Typical)

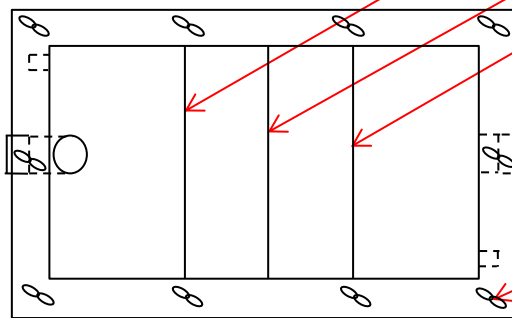

Plan View

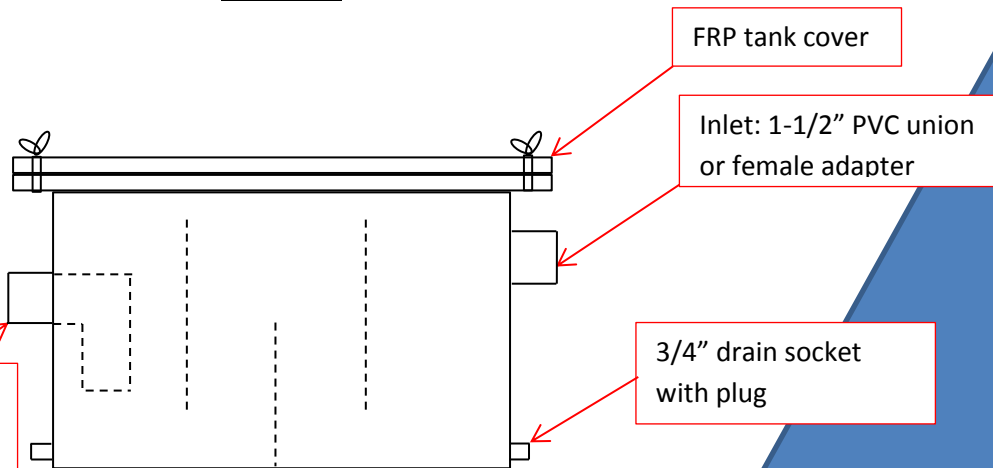

Front View